

AdamPower

ADM57 Series Pulse&Direction,
RS232 Serial Stepper Motor Controller



Contents

A, Overview.....	2
1. Overview.....	2
2. Features.....	2
3. Application.....	2
B, Electrical, Mechanical Instruction.....	3
1. Electrical.....	3
2. Using environment.....	3
3. Specifications and description.....	3
4. Heat dissipation.....	4
C, Terminal and typical application.....	4
1. Stepper driver terminal.....	4
2. Control Signal.....	4
3. Signal timing diagram.....	7
4. Signal control mode.....	8
5. Wiring.....	8
D, Dip switch.....	9
1. Set working current.....	8
2. Set micro-step.....	9
E, Power and Stepper Motor.....	10
F, Protection function.....	11
G, Malfunction & method.....	12
H, Warranty.....	13

ADM57 Stepper Motor Controller

A. Overview:

1. Overview .

ADM57 Miniature integrated stepper motor driver

1. With same size as NEMA23 stepper motor,
2. Built-in 32-bit DSP digital chip.
3. Using new control algorithms such for vibration suppression and low heat-generation
4. Ensure the motor runs smoothly, with low noise and temperature controllable.
5. ADM57 Stepper Driver with Max.Output current: 5.6A, Design for meeting the all of NEMA23 stepper motor application requirement.
6. AdamPower Micro-Step technology, Achieve High subdivision effects through internal algorithms, even in the low micro-step condition, which widely applied in laser wire solutions.
7. Integrated automatic matching function for motor parameters, Optimize the operating parameters, make sure the motors in good performance.
8. ADM57 stepper controller can be assembled as NEMA23 Integrated Stepper Motors

2. Features .

1. Input Voltage: 15VDC ~ 50VDC, Recommend DC36V.
2. Continuous Output Current: 4A, Peak Current: 5.6A
3. Integrated Design for NEMA23 stepper motors directly.
4. Low Vibration, Low Noise, Low Heat, Running Smoothly.
5. Integrated Micro-step function, Smooth filtering Function.
6. 8 Options Micro-step, Max. 1/256 Micro-step.
7. With Over-voltage, Over-Current, Under-Voltage Protection.
8. Stepper Motor Parameters Automatic Matching.

3. Application..

Suitable for a variety of automation equipment and instruments which in small size and small space.

For example: electronic processing equipment, electronic assembly equipment, laser equipment, automatic grabbing equipment, packaging equipment and robots.

✓ Especially good for applications where users expect high smoothness and low noise.

B. Electrical, Mechanical Instruction

1. Electrical. .

Parameters	ADM57			
	Min.	Typical	Max.	Unit
Output Current	0	-	5.6	A
Voltage	+15	+36	+50	Vdc
Logic Input current	6	10	16	mA
Pulse Frequency	0		200	kHz
Pulse High level Width	1.5	-	-	uS
Over-voltage Protection	56	58	60	Vdc
Insulation Resistance	100	-	-	MΩ

2. Using environment

Cooling Method		Natural Cooling or other Air Forced Cooling
Environment	Working Site	Can't be placed next to the hot equipment. To avoid dust, oil mist, corrosive gases, humidity and strong vibration. It is forbidden to flammable gas and conductive dust.
	Temperature	-5°C ~ +45°C
	Humidity	40 ~ 90%RH
	Vibration	10 ~ 55Hz / 0.15mm
Storage Temperature		-20°C ~ +65°C
Altitude		≤1000m
Weight		120g (Excluding Motor)

3. Specifications and description.

ADM57 Stepper Motor Driver is design for assembly NEMA23 Integrated Stepper Motor.

We supply 0.6Nm, 1.0Nm, 2.1Nm, 4.5Nm, 8.5Nm, **NEMA23** Integrated Stepper Motors#ADM57-06, 10, 20

Model No.	Holding Torque Nm	Length mm	Shaft diameter
ADM57-06	0.6	57-42	6.35mm
ADM57-10	1.0	57-56	6.35mm
ADM57-20	2.1	57-76	8mm

ADM57-45	4.5	86-80	12.7mm
ADM57-85	8.5	86-114	14mm
Other	Even support 0.9° degree NEMA23 stepper motor		

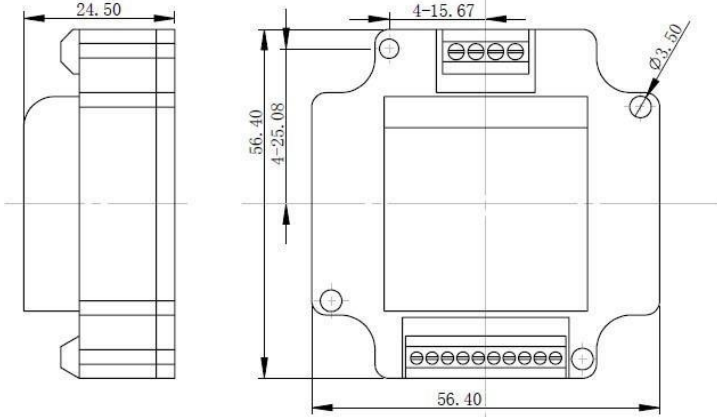

ADM57 Stepper motor controller size ↑

4. Heat dissipation.

The working Site Temperature should be: $-5^{\circ}\text{C} \sim 45^{\circ}\text{C}$,

ADM57 stepper motor driver' s temperature normally not higher than 60°C .

Stepper Motor' s temperature not higher than 70°C ,

If necessary please make sure the situation with effective temperature.

Recommend the Cooling Flange when assembly the integrated stepper motor..

C. Terminal and typical application

1. Terminal description.

Green 10Pins 2.55 interval terminals:

Pin No.	Name	Description
1	+VDC	Supply voltage: 12-50VDC

2	GND	Supply Voltage Ground: GND/0V
3	PUL+	Pulse Control Signal Input: Rising Edge effective, PUL high level:4 ~ 5V,, Low level: 0~5V .
4	PUL-	Make sure pulse signal effective, pulse width \geq 1.2 μ s, Add the resistance for power supply.
5	DIR+	Direction Signal: high/low level signal : pulse width > 5 μ s · High level: 4 ~ 5V · Low level: 0 ~ 0.5V
6	DIR-	
7	ENA+	Enable sigla : enable/disable. If ENA+ connect +5V, ENA- connect low level(or Internal optocoupler on), stepper controller will turn off the current, motor in free state, no feedback even send pulses.
8	ENA-	
9	TXD	To the TX pin on user device
10	RXD	To the RX pin on user device

✓ Note: Pulse Signal, Direction Signal, Enable Signal support 5V signal only.

If Control Signal: +12V, please add resistance 1K Ohm



If Control Signal: +24V, please add resistance 2.2K Ohm

4Pins 3.5mm interval Screw Terminal:

Pin No.	Name	Description
1	A+	2Phase Hybrid Stepper Motor Phase A+
2	A-	2Phase Hybrid Stepper Motor Phase A-
3	B+	2Phase Hybrid Stepper Motor Phase B+
4	B-	2Phase Hybrid Stepper Motor Phase B-

LED indicator description:

LED Indicator in Green Color when Power on ; light off when power off; When malfunction Red LED indicator flashing every 5 seconds.

S/N	Flashing	Red indicator flashing	Malfunction description
1	1 time		Overcurrent fault, or phase to phase short circuit
2	2 times		Overvoltage fault (Vdc \geq 60V)

Controller will shut down when malfunction, and supply error code, and error will be

save to EEPROM of stepper motor controller, Max. storage 10 errors. When restart power the malfunction will be clear.

2. Control Signal

ADM57 Stepper Motor Driver using differential interface circuit, applicable to differential signal and single ended common negative / common positive signal.

ADM57 has built-in high-speed optocoupler, which allows to receive signals from long-line driver, open collector and PNP output circuit. In harsh environment, we recommend using long line driver circuit to enhance the anti-interference ability of the driver.

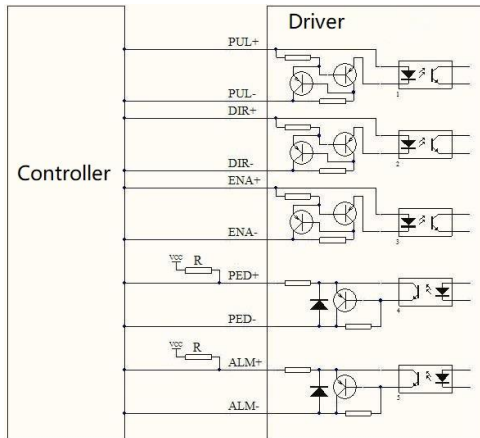

↑ Input signal **differential wiring**

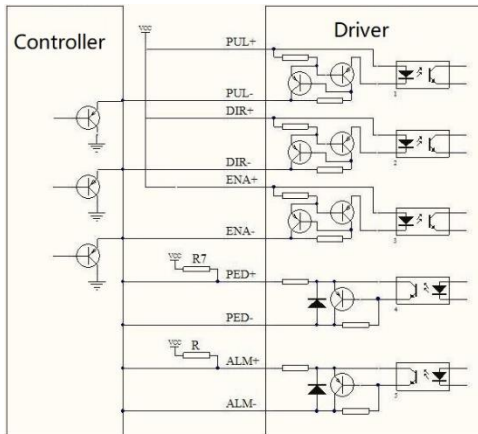

↑ Input signal Single ended **common anode** connection

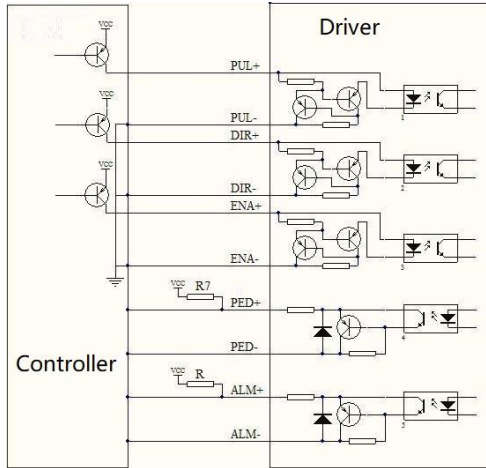

↑ Input signal Single ended cathode connection

✓ Note: Above Signal input voltage: 4.5 ~ 5VDC.

If Control Signal: +12V, please add resistance 1K Ohm

If Control Signal: +24V, please add resistance 2.2K Ohm

3. Signal timing diagram.

To avoid some misoperation and deviation, PUL-, DIR- and ENA- as below:

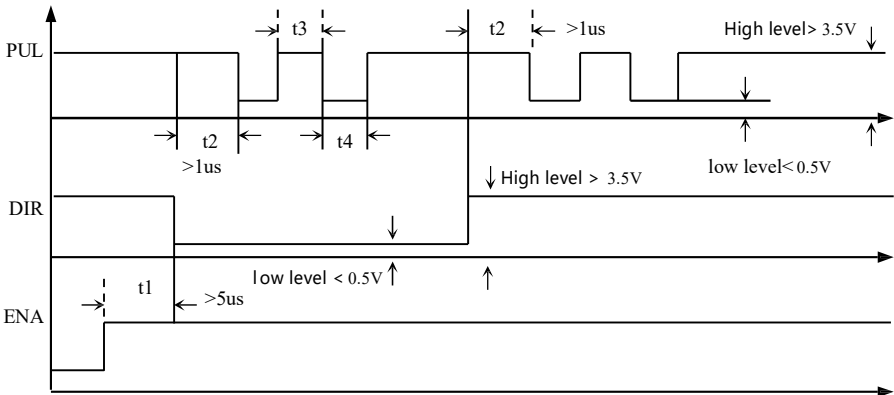

Note:

- 1) t1 : ENA at least 5 μ s earlier than DIR, confirm High.
- 2) t2 : DIR at least 1 μ s earlier than PUL descant edge, confirm status is High or Low.
- 3) t3 : Pulse Width \geq 1.5 μ s.
- 4) t4 : Low level width \geq 1.5 μ s.

4. Signal control mode.

Pulse trigger edge: Set Pulse Rising edge & Descent edge via PC software.

5. Wiring.

- ✓ In order to prevent the driver from being disturbed, It is recommended to use shielded cable for control signals. And the shielding layer is shorted to the ground wire, except for special requirements.
- ✓ The shielded cable of the control signal cable is grounded at one end: The upper end of the shielded wire is grounded. The drive of the shielded wire is suspended at one end. Only grounding at the same point is allowed in the same machine. If it is not a real ground wire, it may cause serious interference.
- ✓ At this point, the shield is not connected. If conditions permit, the thermal grounding technique is most effective for shielding.
- ✓ Pulse & direction signal lines is not allowed to be bundled with motor wires. It is best to separate at least 10cm or more. Otherwise, the motor noise is likely to interfere with the pulse direction signal, causing the motor to be misaligned, or the system is unstable and other faults.
- ✓ If one power supply is available for multiple drives, Parallel connections should be made at the power supply, not allowed to go to one and then to another for chain connection.
- ✓ Do not plug or unplug the drive terminals when power on. when the live motor stops, there is still a large current flowing through the coil, and the plug-in terminal will cause a huge moment to induce the electromotive force to burn the driver.
- ✓ It is strictly forbidden to add tin to the wire lead and connect it to the terminals, Otherwise, the terminal may be damaged by overheating due to large contact resistance.
- ✓ To prevent accidental short circuit and damage the driver, the wiring head should not be exposed outside the terminal.

D. DIP Switch

ADM57 stepper motor driver, using 6 DIP switch for set the **current** and **Micro-step**:

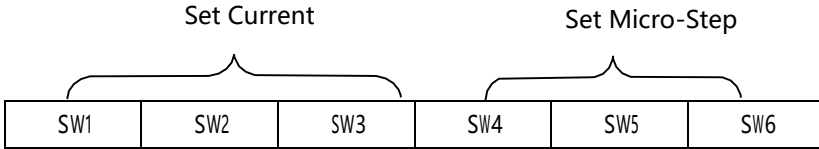

1. Set working current.

Output Peak current	Mean	S1	S2	S3
Default 1.5A	1.1A	ON	ON	ON
2.1A	1.5A	OFF	ON	ON
2.7A	1.9A	ON	OFF	ON
3.2A	2.3A	OFF	OFF	ON
3.8A	2.7A	ON	ON	OFF
4.3A	3.1A	OFF	ON	OFF
4.9A	3.5A	ON	OFF	OFF
5.6A	4.0A	OFF	OFF	OFF

✓ Note: The default peak current(1.5A), also it can be set through Serial Command, and the Peak Current range is: 0.1A ~ 5.6A

✓ When the pulse stops for about 0.2 seconds, the current is automatically reduced to about half (60% of the actual value), and the motor and driver's heat is reduced to 36% theoretically

2. Set Micro-step.

Pulses/revolution (Micro-step)	S4	S5	S6
Default 400(1/2 Micro-Step)	ON	ON	ON
800 (1/4 Micro-Step)	OFF	ON	ON
1600 (1/8 Micro-Step)	ON	OFF	ON
3200 (1/16 Micro-Step)	OFF	OFF	ON
4000 (1/20 Micro-Step)	ON	ON	OFF
5000 (1/25 Micro-Step)	OFF	ON	OFF
6400 (1/32 Micro-Step)	ON	OFF	OFF
12800 (1/64 Micro-Step)	OFF	OFF	OFF

- ✓ Note : The default 1/2 micro-step (400pulses/revolution), can be set through Serial Command, Micro-step range: 200 ~ 51200pulses/revolution (1/2 Micro-step to 1/256 Micro-step).

E. Power supply and Stepper Motor.

1. Power supply: 15VDC ~ 50VDC, Recommend **DC36V**.

ADM57 driver is preferably powered by regulated DC power supply or switching power supply. and the power supply shall be noted that the output current range of the switching power supply shall be set to the maximum.

✓ Note :

- 1). When wiring, pay attention to the positive and negative poles of the power supply, and do not reverse connect.
- 2). When switching power supply is adopted, the output current of the power supply shall be greater than or equal to the working current of the driver
- 3). If multiple drives share one power supply, ensure that the power supply is large enough.

2. Stepper Motor

ADM57 stepper motor driver can be use to drive 4wires, 6 wires, 8 wires, 2 phase hybrid stepper motor. Recommend **2 phase 4 wires hybrid stepper motor**.

Step angles of **1.8 degrees** and 0.9 degrees are applicable.

F. Protection function .

1. Over-voltage Protection:

ADM57 Stepper Motor Driver will be stop working when the input voltage is over 60VDC, Restart the power when changed the correct voltage.

2. Under-voltage Protection:

ADM57 Stepper Motor Driver will be stop working when the input voltage is less 10VDC, Restart the power when changed the correct voltage.

3. Under-current Protection:

ADM57 Stepper Motor Driver will be stop working when the over-current is occurred, Restart the power when changed the correct voltage.

✓ ✓ Note: The ADM57 Stepper Motor Driver have no protection when **reverse polarity** of the power supply.

G. Malfunction and Method .

Malfunction	Reason	Method
Motor Don' t Run	Indicator light off	Check the power supply and circuit
	Shaft with torque	Pulse signal weak, add current to 7-16mA
	Micro-step is low	Check & set the micro-step
	Driver Protected	Restart the power
	ENA signal weak	Add signal or not connect it
	control signal no answer	Not power on
	Motor Circuit breaker	Check and modify connection
	Over-voltage/under-voltage	Check the power supply
	Motor Driver broken	Change the new driver
Position Incorrect	Signal interference	suppress interference
	Shield ground wire not	Modify the connection
	Motor Circuit breaker	Check and modify connection
	Micro-step is low	Check & set the micro-step
Stall when accelerate	Acceleration time is too short	Add accelerate time
	Motor torque is small	Change motor
	Voltage is mall	Increase voltage

1). Micro-Step advantages:

- Improve the step uniformity& control accuracy.
- Reduce motor vibration.
- Effectively reduce torque ripple and increase output torque.

2). Motor runs in one direction only ?

- The direction signal may be too weak,Wiring polarity is wrong,

The signal voltage is too high to burn out the direction current limiting resistor.

- Pulse mode does not match, signal is Pulse/Direction.

H. Warranty

1. One Year warranty.

Our company provides a one-year warranty on the raw materials and process defects of its products from the date of shipment.

During the warranty period, our company provides free repair service for defective products.

2. No warranty issue

- Improper wiring, such as the positive and negative poles of the power supply, and the plugging and unplugging when power on.
- Unauthorized changes to internal devices.
- Exceeding electrical and environmental requirements.
- Working situation with bad heat dissipation.

AdamPower[®]

Simon Wu

Whatsapp: +86 156 5677 5078

Shenzhen Adam Technology Co.,Ltd